



NATERIAL

82090147

KORAO
Axess

FR / Notice de Montage

ES / Instrucciones de montaje

PT / Manual de montagem

IT / Istruzioni di montaggio

DE / Montageanleitung

EN / Assembly instructions

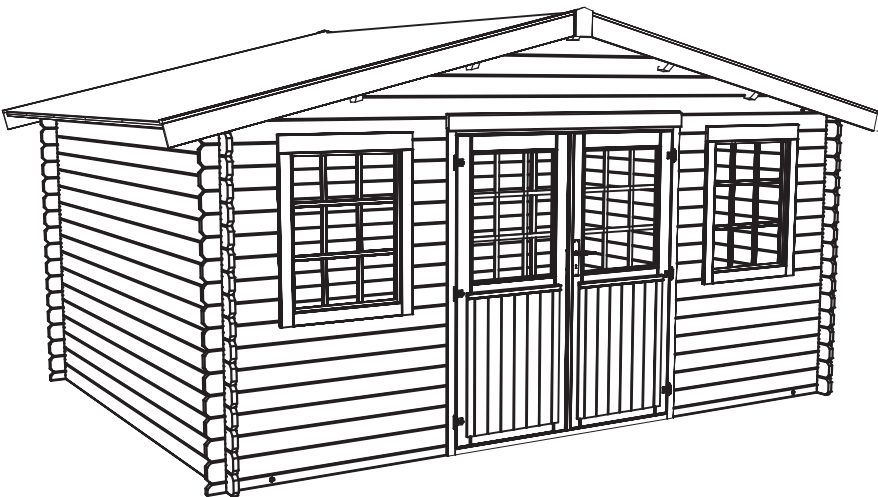

[roof 1 year
guarantee]

(FR) CONSEILS GÉNÉRAUX PRÉALABLES À LIRE ATTENTIVEMENT

Nous vous remercions pour l'acquisition de ce chalet, et nous vous invitons à lire attentivement la notice avant de commencer à déballer le colis.

STOCKAGE DU COLIS AVANT LE MONTAGE DE L'ABRI

Stockez votre colis dans un endroit sec et ventilé, à l'abri du soleil et des intempéries (emballage non hermétique). Le colis et les pièces doivent être posés à plat sur le sol afin d'éviter les déformations. Procédez au montage dans un délai minimum après réception du produit (le délai de service après-vente est de 10 jours maximum après la date d'achat).

CONSIGNES DE SÉCURITÉ

Les pièces en bois peuvent présenter un risque d'écharde. Manipulez les bois avec précaution, avec des gants de protection. Vérifiez qu'aucun clou, vis ou agrafe ne dépasse des pièces assemblées. Toujours suivre attentivement les instructions et l'ordre de montage de la présente notice. Ces instructions sont données pour votre sécurité. Lisez-les attentivement avant utilisation et conservez-les pour une consultation ultérieure. PRODUIT NON DESTINÉ À L'HABITATION.

OPÉRATION DE MONTAGE

Il est indispensable d'installer l'abri dans un endroit protégé des vents violents. Ne pas exposer les pièces en bois et le revêtement de toiture au soleil durant le montage. Commencez par trier, identifier et vérifier les pièces par rapport à la nomenclature, en vous référant à leur section et à leur longueur. Avant de commencer, assurez-vous que la base sur laquelle l'abri sera installé soit parfaitement plane, et de niveau. L'option plancher est composée de chevrons et de plaques/planches à assembler sur un sol ferme et stable. Mettre des supports (blocs ou poutres béton de 40mm min. d'épaisseur) pour assurer une bonne ventilation. Pour l'abri sans plancher, la dalle béton doit avoir des dimensions égales ou supérieures aux dimensions du plancher. Vérifiez son équerage en prenant les diagonales. Les pièces sont toutes aux bonnes dimensions, ne pas les couper. Contrôlez régulièrement le niveau et l'équerage de ce que vous montez. Pour toutes les pièces assemblées par vis, il est conseillé de préférer la première pièce, sinon le bois risque de se fendre lors du serrage.

RENFORTS INTÉRIEURS (SI ABRI MASSIF)

Les lattes de renfort à placer aux angles à l'intérieur servent à solidariser la pointe au corps de l'abri (1 seule vis aux extrémités des renforts). Vérifiez régulièrement ces fixations, et les ajuster en fonction du travail du bois (sécheresse, humidité,...)

FIXATION DE L'ABRI

Toujours fixer solidement l'abri au sol par tous moyens appropriés (non fournis). Si option plancher : le fixer au corps de l'abri, et mettre du poids pour le lester. Les moyens de fixation ne sont pas fournis.

TOITURE

Commencez la pose du revêtement de toiture par le bas du toit, en laissant dépasser le roofing de 40mm à l'avant et à l'arrière, le rabattre sur le chant du toit.

Laissez dépasser le roofing de 70mm sur le côté, puis le replier sous la plaque de toit et le fixer à l'aide des clous à tête large (tous les 200mm max.).

Finissez par apposer les planches de rive à l'aide de vis.

REMARQUES

Le bois de sapin est un matériau vivant qui ne cesse de travailler, et peut présenter certaines déformations (bois légèrement voilés ou gondolés), des fentes, des nœuds tombants et des poches de résine.

Ceci est normal, et ne met pas en péril la longévité de votre abri. L'application de pâte à bois (non fournie) peut-être une solution simple.

Pour les abris à emboîtement, veuillez noter que toutes les planches ont toujours une belle face qui doit être positionnée à l'extérieur de l'abri (la face cachée peut présenter certains défauts de rabotage, écorce, fentes, ...)

ENTRETIEN

Il est impératif de traiter l'abri à l'aide d'un produit de protection pour bois à l'extérieur, contenant des agents fongicides, insecticides et anti-UV. Minimum 2 couches à l'extérieur + 1 couche à l'intérieur.

Renouvelez régulièrement l'opération selon l'usage.

SERVICE APRÈS-VENTE (SAV)

Tout manquement doit être signalé au moyen du formulaire SAV (disponible en magasin) dans les 10 jours suivant l'achat, facture ou ticket de caisse à l'appui.

Notre SAV consiste en la réparation ou au remplacement de la pièce défectueuse. Les éventuels frais de pose et de dépose ne sont pas pris en charge.

Tout client prenant l'initiative d'intervenir sur un produit sans validation préalable par le fabricant décharge de ce fait le fabricant de toute responsabilité. Pour toute demande de SAV, veuillez-vous conformer strictement à la procédure disponible en magasin (Procédure SAV) : ticket de caisse ou preuve d'achat, référence du produit, numéro du colis référence exacte de la pièce défectueuse.

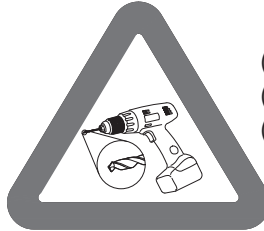
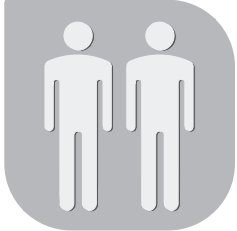
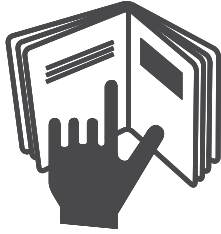





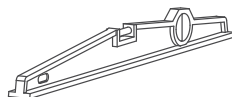
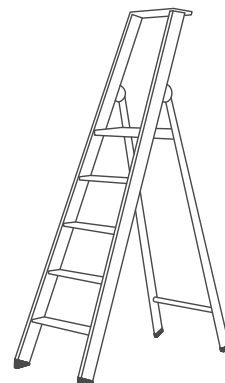
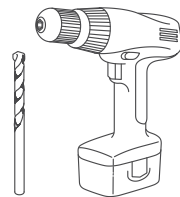
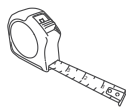
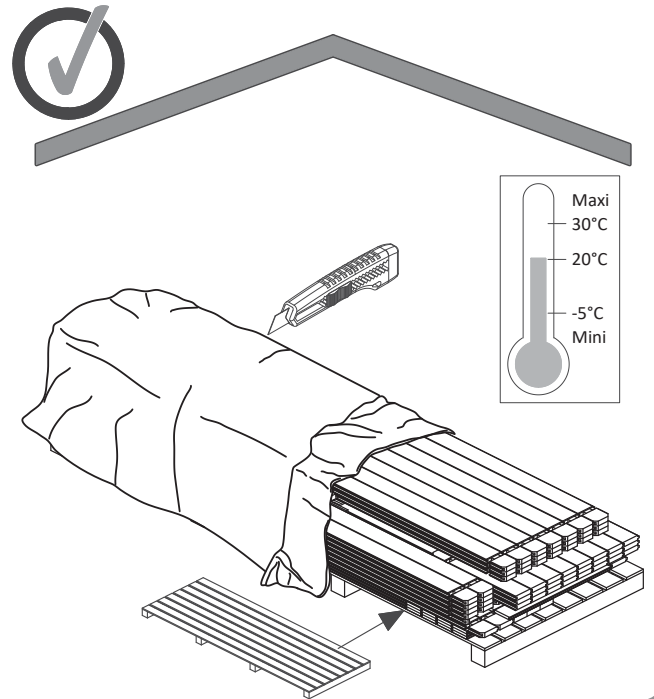
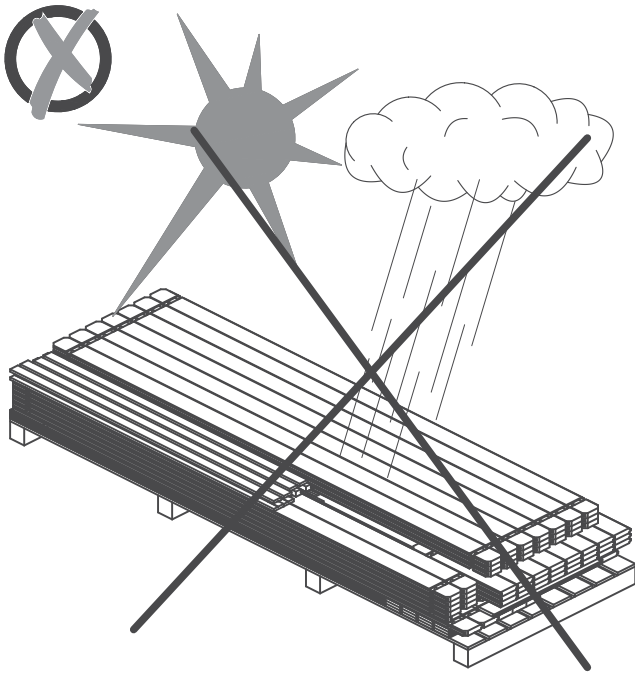

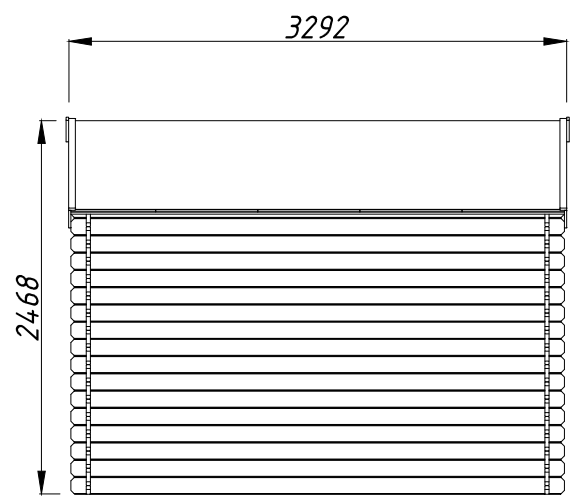
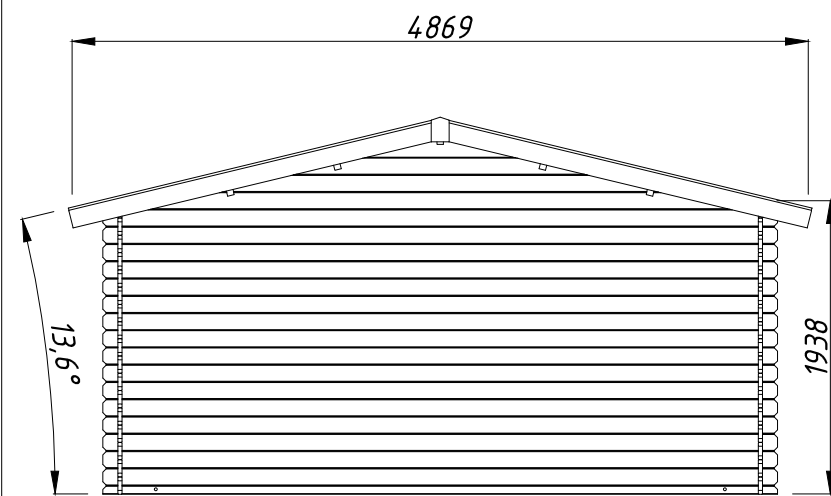
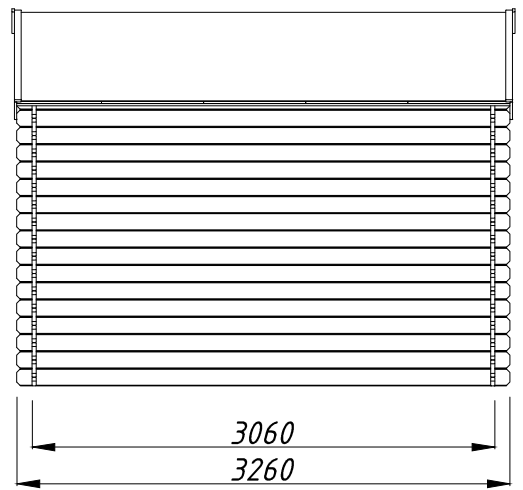

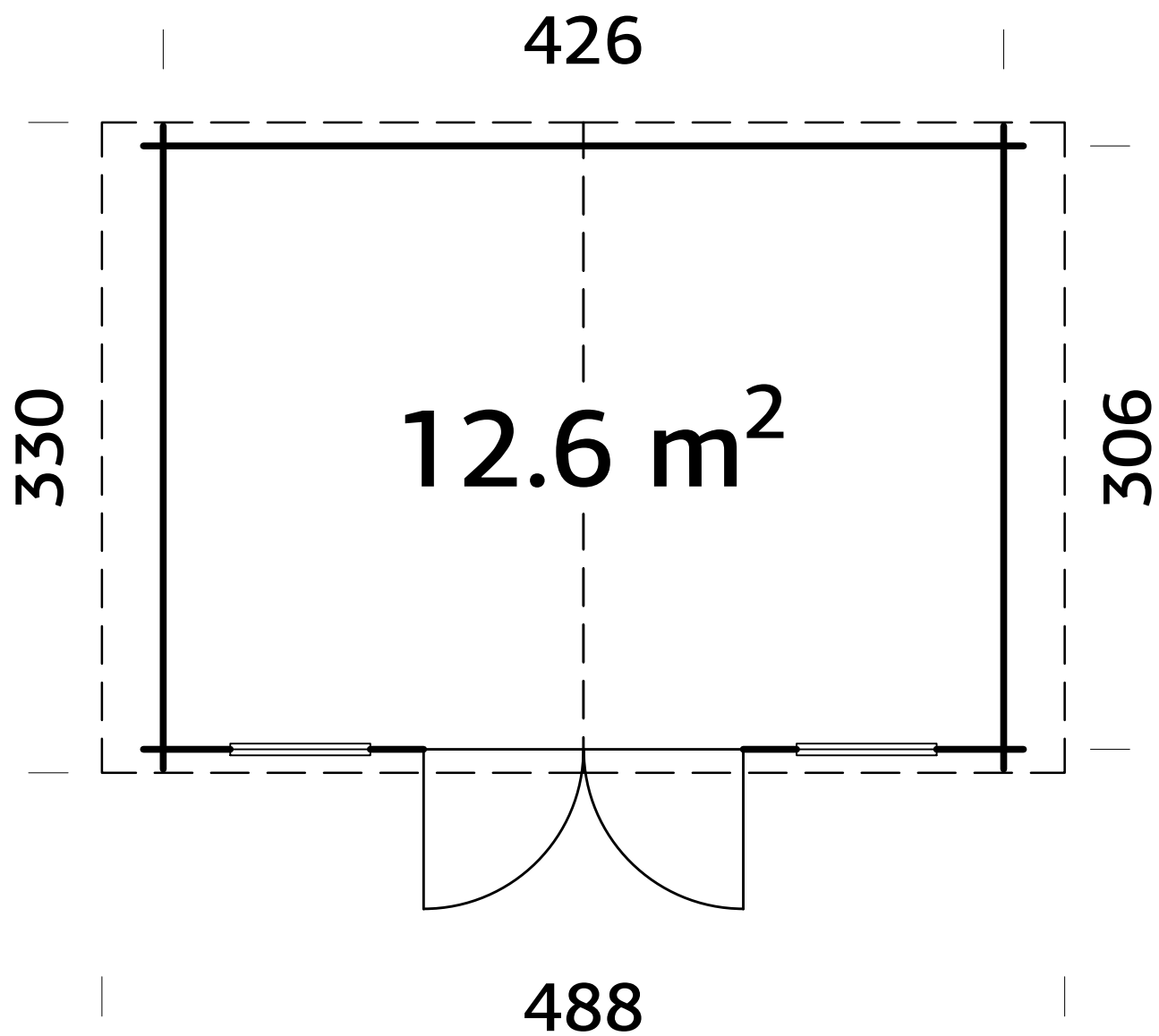
(EN) Predrill
(FR) Préforer
(DE) Vorbohren

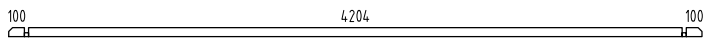
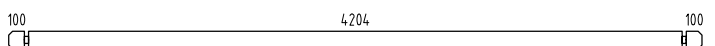
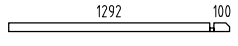
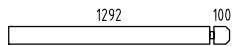
(IT) Preforare
(ES) Preforar
previamente
(PT) Perfuração

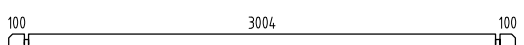
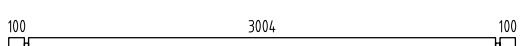
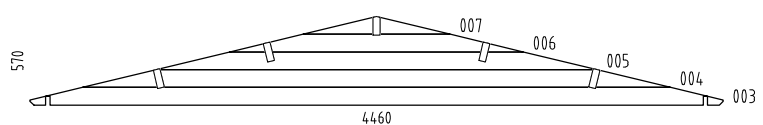
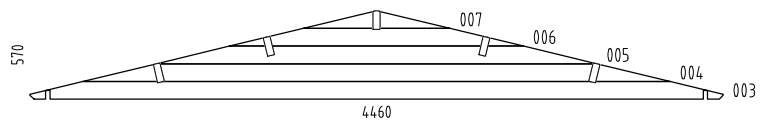

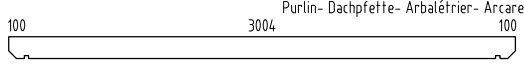
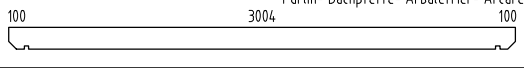
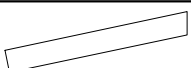

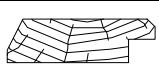



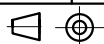

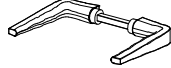
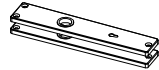
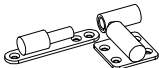











Pos	SPECIFICATION-STÜCKLISTE-NOMENCLATURE-ELEMENTI-ESPECIFICACIÓN FR28-4533	Pcs	Profile (mm)	Length (mm)
001		1	28x57	4460
002		16+1	28x114	4460
008		2	28x57	1420
009		16	28x114	1420
010		16	28x114	440
011		16	28x114	270
012		32+1	28x114	3260
013		2	28x114	3260
W1-1		1		
W2-1		1		
Det1	Detail - Detail - Detail - Dettaglio - Detalle 	2	16x120	162
OSB3_1	OSB3_T&G4_15mm 	10	675x15	2500
PR1	Purlin- Dachpfette- Arbalétrier- Arcareccio- Correa 	4	44x140	3260
PR2	Purlin- Dachpfette- Arbalétrier- Arcareccio- Correa 	1	44x140	3260
FaB3-1	Facia board- Giebelblende- Écran frontal- Schermo frontone- Tabla de facia 	4	16x120	2520
RE1-1	Roof edge reinforcement- Dachrandleiste- Baguette en bordure du toit- Rinforzo bordo tetto- Refuerzo borde tejado 16x45 	4	16x45	1630
YPapp-1	Roof felt- Dachpappe- Carton bitume- Cartone catramato- Filtro de tejado 	2		10000
SiS7-1	Side slat - Randleiste - Baguette en bordure - Listello bordo 7 	2	28x95	1650
StB1-1	Storm brace- Sturmleiste- Protection contre le vent- Antivento- Protector contra tormentas 	4	25x45	1940
WB1-1	Wind brace- Windbrett- Madrier contre le vent- Tavola vento- Tabla contra el viento 	4	16x45	2520

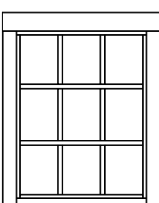

Pos	SPECIFICATION-STÜCKLISTE-NOMENCLATURE-ELEMENTI-ESPECIFICACIÓN FR28-4533	Pcs	Profile (mm)	Length (mm)
Fim	-Fixing kit- Befestigungsset- Moyens de fixation- Materiale di fissaggio- Kit de fijación	1		
QPOYP 8x60Zn	Bolt -Schloss-schraube -Boulon- Bullone- Perno- M8x60mm PUP0		8	
QLIUHb	Door fittings- Türbeschlag- Ferrure- Ferramenta porta- Manilla puerta- QLIUHb		1	
QULK AK-2	Door fittings- Türbeschlag- Ferrure- Ferramenta porta- Manilla puerta- QULKAK-2		1	
QHP15 x57Zn	Door hinge- Türbänder- Charniere de porte- Cerniere porta- Bisagra de puerta- QHP15x57Zn		6	
QRV1 20Zn	Keeper- Schliessblech- Tole- Lamiera- Aldaba de candado- 120Zn		2	
QMUK K8Zn	Nut- Schraubenmutter- Écrou- Dado- Tuerca- M8mm		8	
QNA2 x16Zn	Roofnail- Dachpappnagel- Clou pour carton bitumé- Chiodo di cartone catramato- Tachuela fieltro tejado- 2.0x16mm		300	
QKRPP2 _5x16Zn	Screw- Schraube- Vis- Vite- Tornillo- 2.5x16mm Zn		4	
QKRPP3 _5x25Zn	Screw- Schraube- Vis- Vite- Tornillo- 3.5x25mm Zn		24	
QKRPP3 _5x40Zn	Screw- Schraube- Vis- Vite- Tornillo- 3.5x40mm		60	
QKRPP 3x20Zn	Screw- Schraube- Vis- Vite- Tornillo- 3x20mm		32	
QKRPP 3x30Zn	Screw- Schraube- Vis- Vite- Tornillo- 3x30mm		30	
QKRPP4 _5x70Zn	Screw- Schraube- Vis- Vite- Tornillo- 4.5x70mm		10	
QKRPP 4x50Zn	Screw- Schraube- Vis- Vite- Tornillo- 4x50mm Zn		350	
QKRPP 5x90Zn	Screw- Schraube- Vis- Vite- Tornillo- 5x90mm		8	
QKRPP6 x120Zn	Screw- Schraube- Vis- Vite- Tornillo- 6x120mm		20	
QSE8 x20Zn	Washer- Dichtscheibe- Joint- Rondella- Arandela- 8x20mm		8	
QSE21 x25Zn	Washer- Dichtscheibe- Joint- Rondella- Arandela- 21x25mm		2	
A28-42	Window - Fenster - Fenetre - Finestra-Ventana 700x882   600x782mm		2	

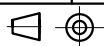

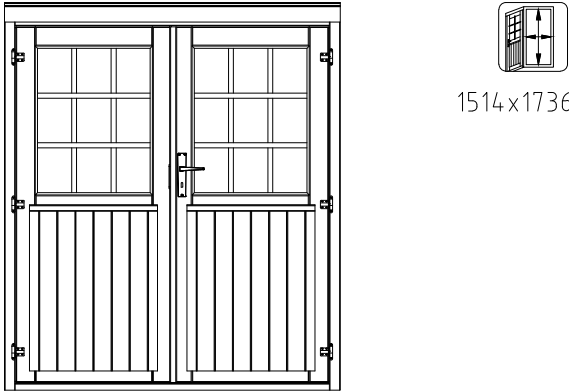
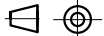
Pos	SPECIFICATION-STÜCKLISTE-NOMENCLATURE-ELEMENTI-ESPECIFICACIÓN FR28-4533	Pcs	Profile (mm)	Length (mm)
TU28 -48P	<p style="text-align: center;">Door - Tür - Porte - Porta-Puerta 1610x1824</p>  <p style="text-align: center;">1514x1736mm</p>	1		
	Object name FR28-4533	Page 3/3		

- (EN) Laying on concrete slabs (not included)
- (FR) Pose sur dalle béton (non inclus)
- (DE) Montage auf Betondielen (nicht einbegriffen)
- (IT) Posto su pavimenti in cemento (non incluso)
- (ES) Colocar sobre losa de hormigón (no incluida)
- (PT) Montagem sobre laje de betão (não incluído)

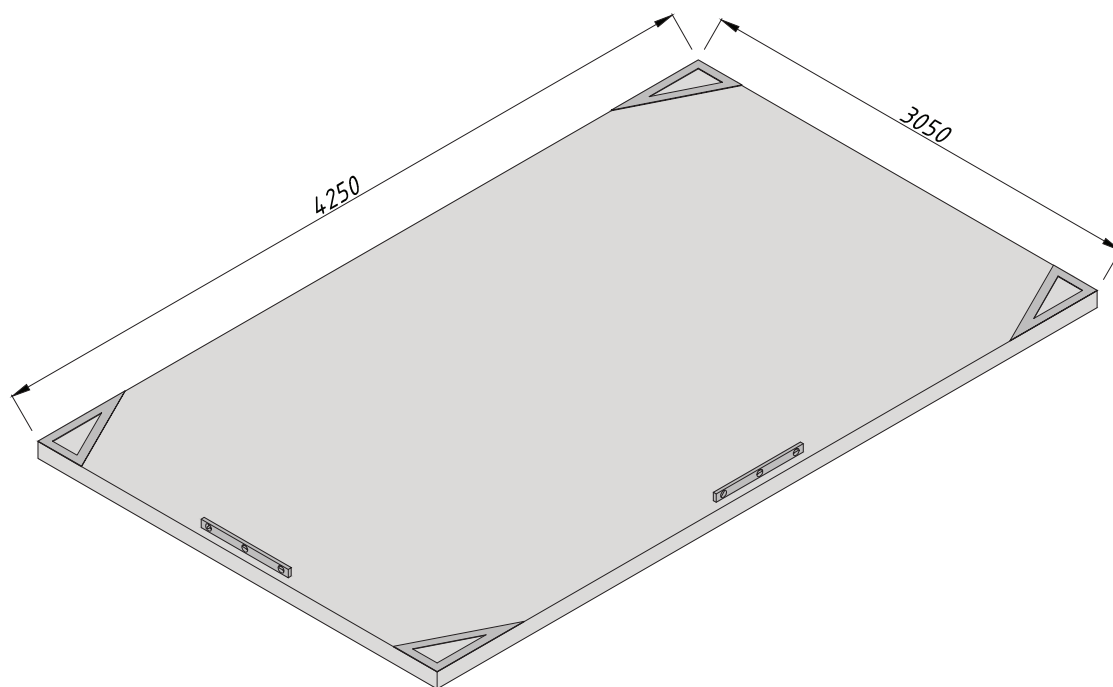

1

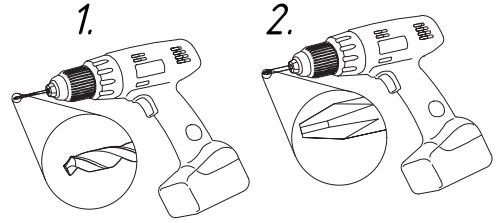

- 001 x1
- 008 x2
- 012 x2
- Ø4,5x70 x6

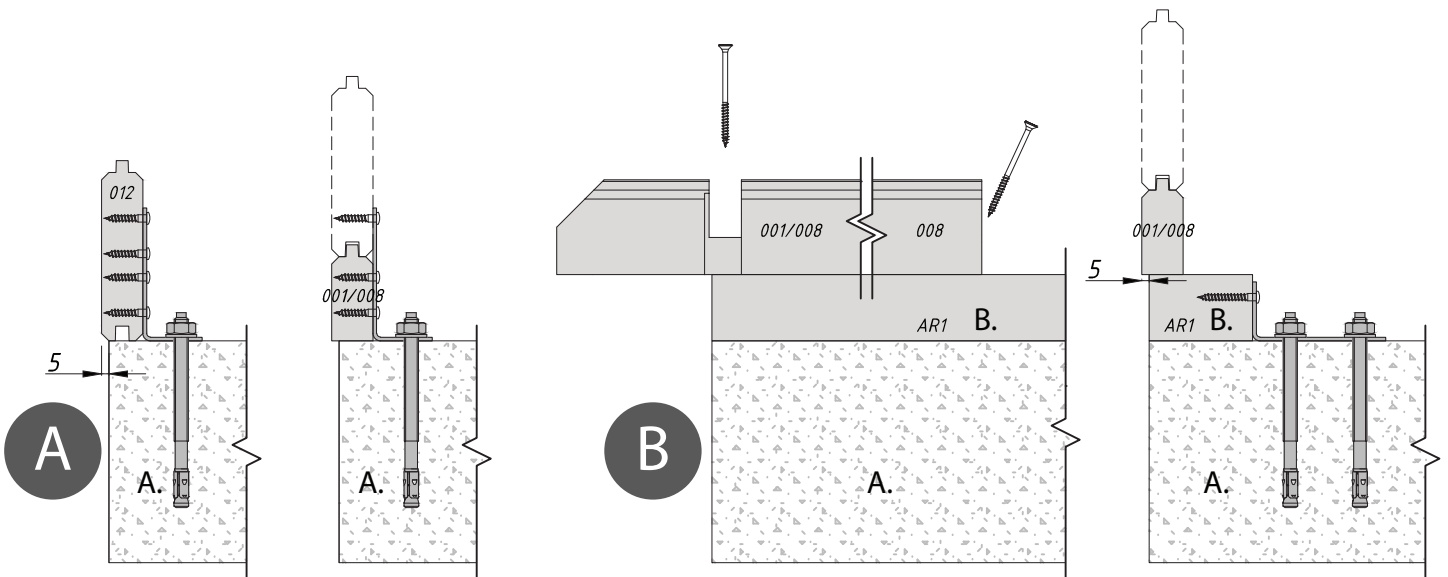
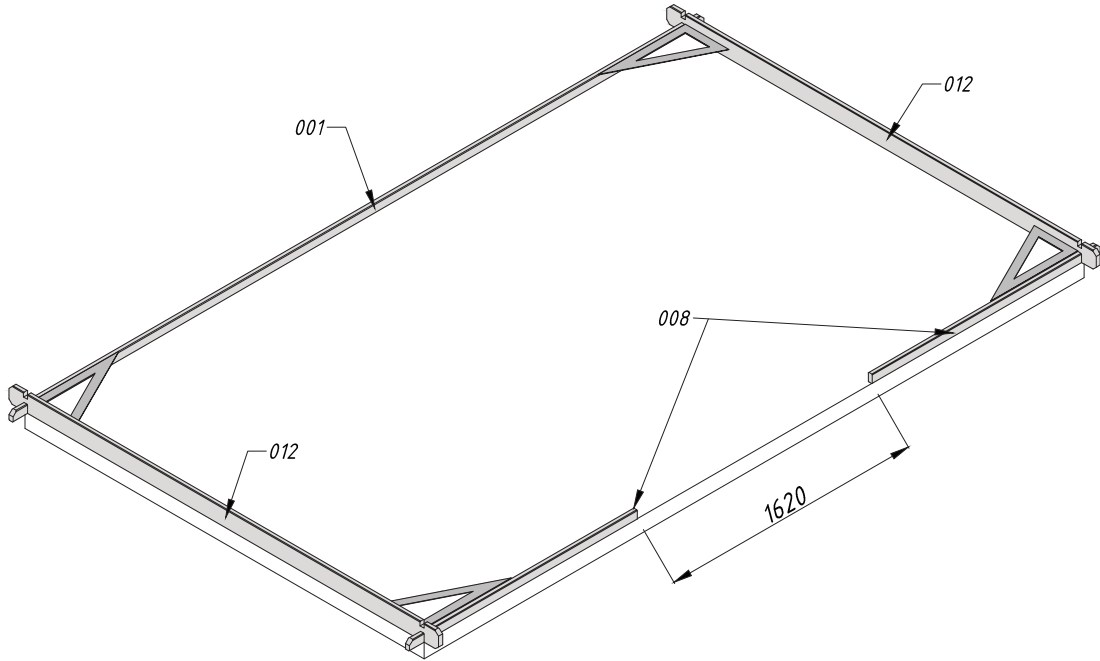

FR A. Pose sur dalle beton (quincaillerie de fixation non inclus)
 B. Pose sur plancher (quincaillerie de fixation non inclus et plancher en option)

EN A. Laying on concrete slabs (fixings not included)
 B. Laying on wooden floor (fixings not included, floor as option)

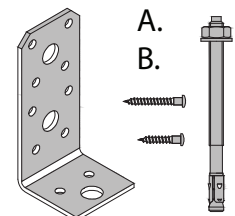

2

- 002 x7
- 009 x14
- 012 x14
- Ø3,5x40 x2
- Ø5x90 x8

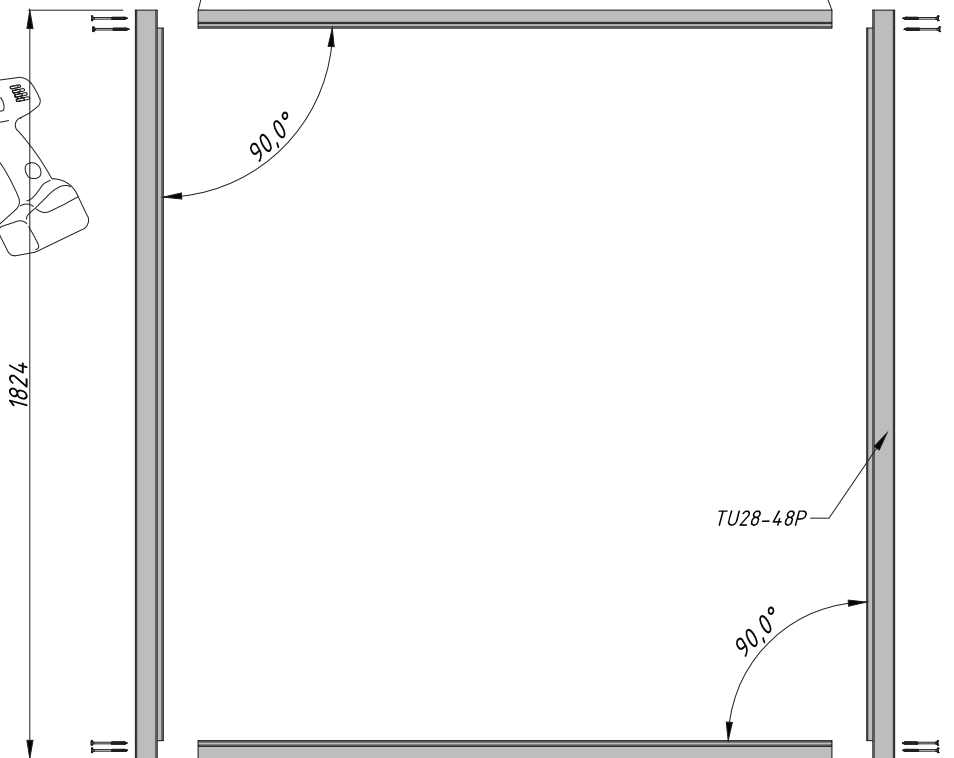
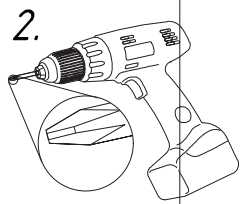
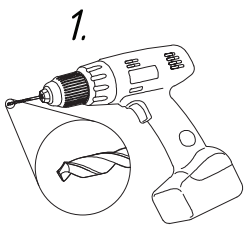
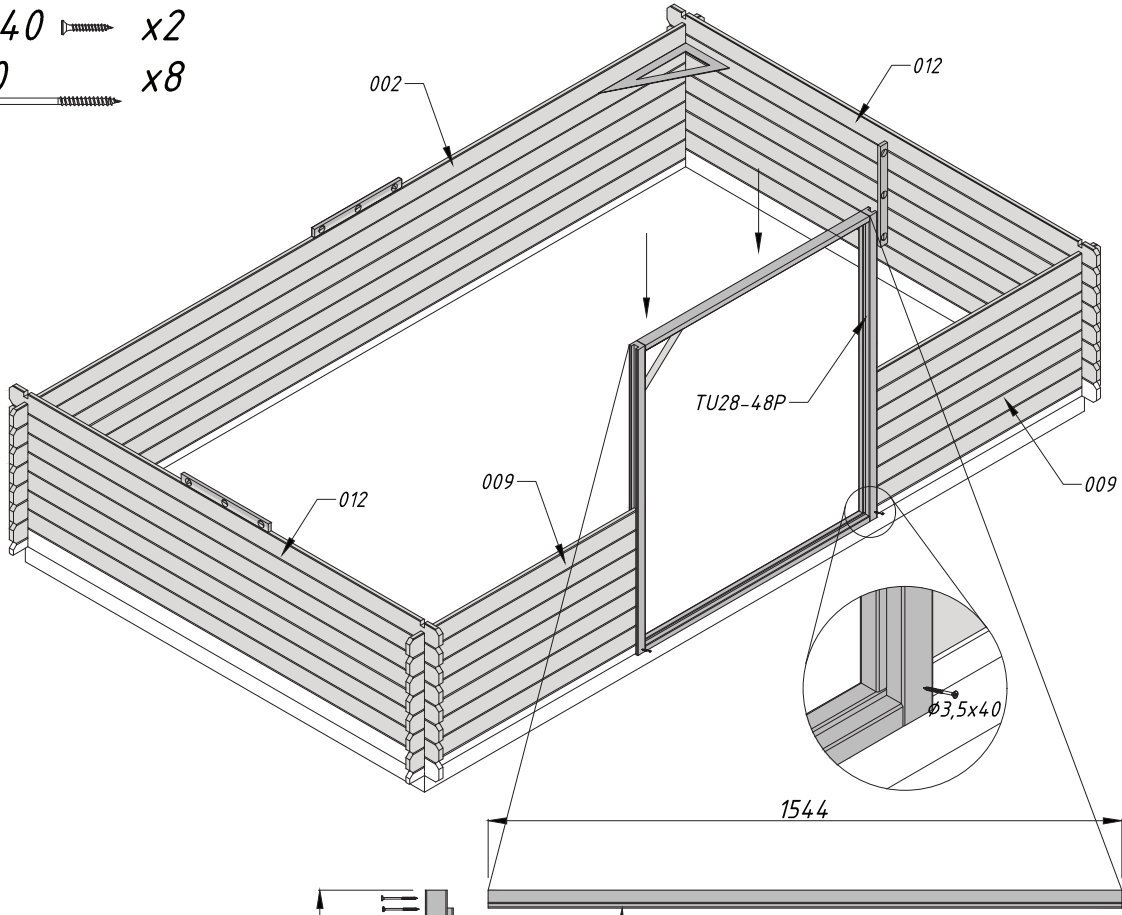
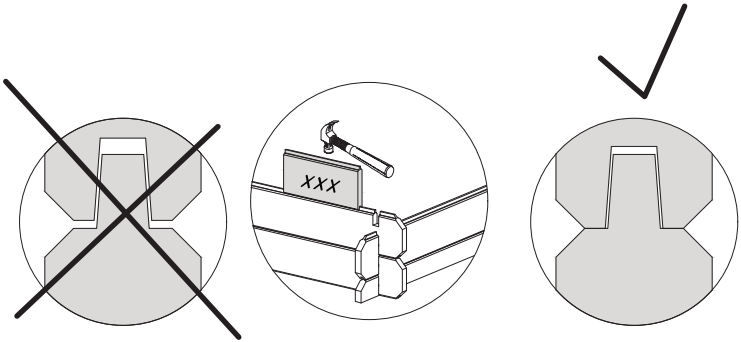

3

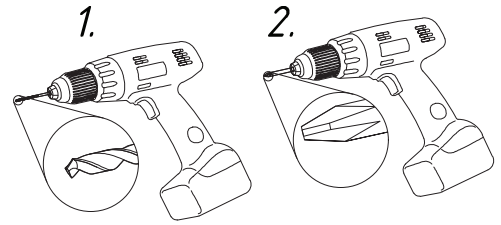

- 002 x8
- 010 x16
- 011 x16
- 012 x16
- A28-42 x2
- Ø3x20 x16

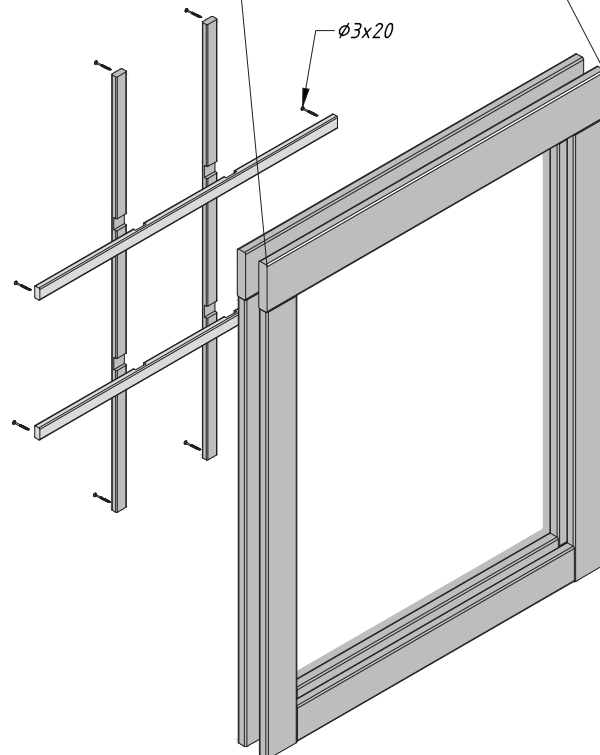
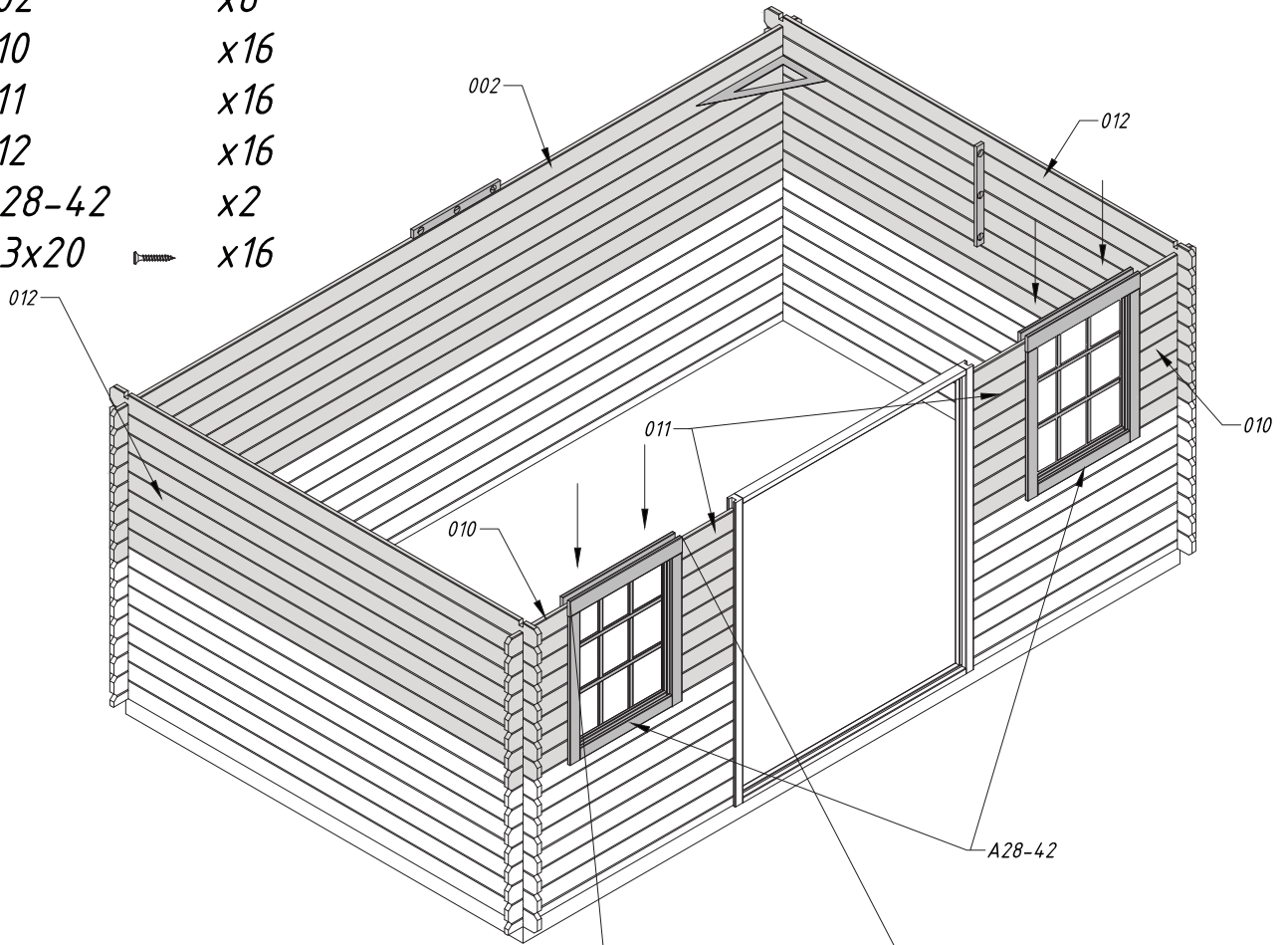

4

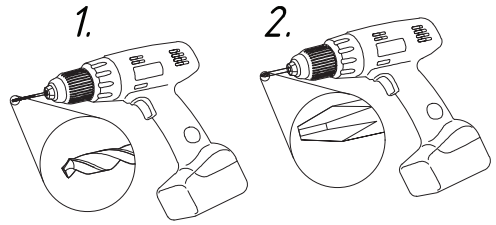

- 002 x1
- 009 x2
- 013 x2
- W1-1 x1
- W2-1 x1
- StB1-1 x4
- M8x60 x8
- Ø4,5x70 x4

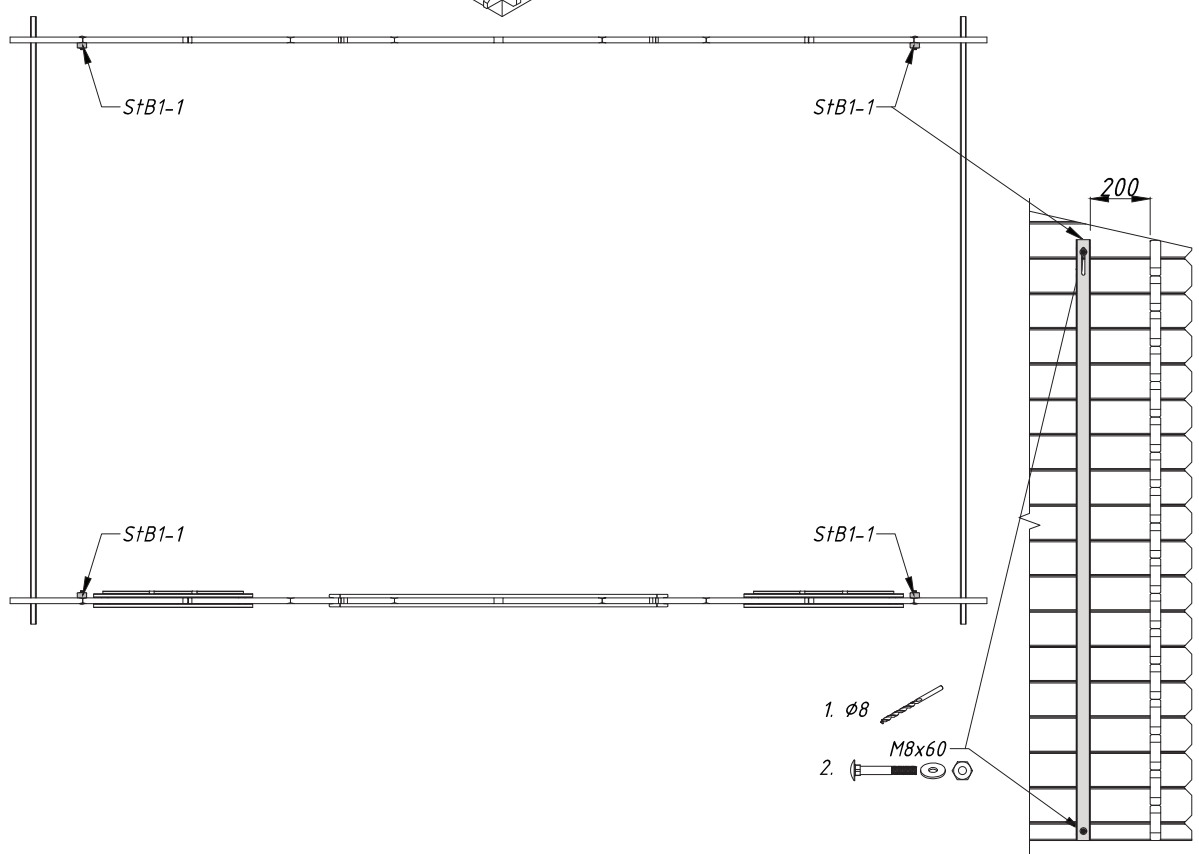
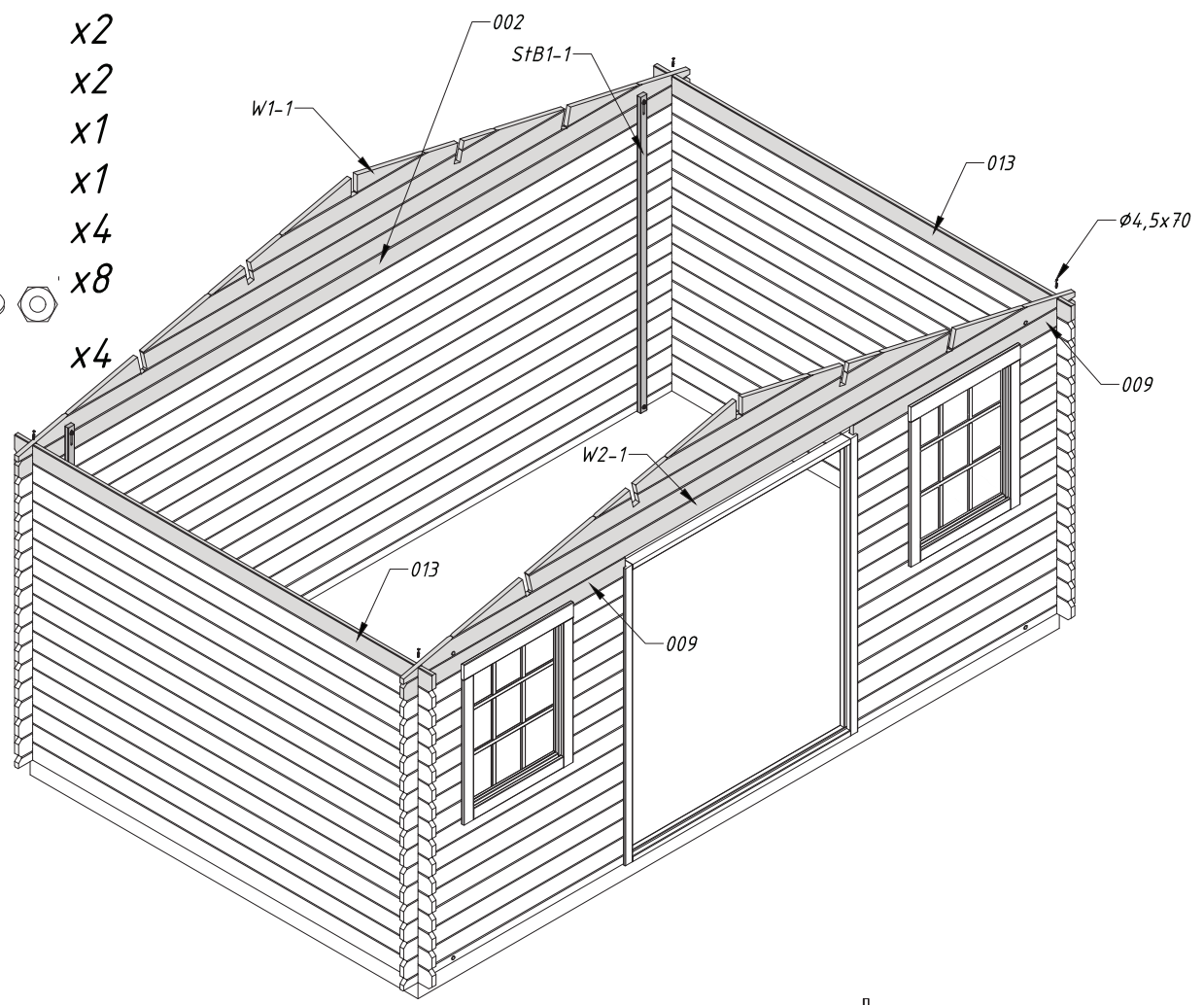

5

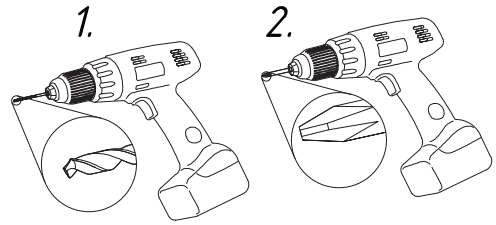

PR1
PR2
Ø6x120

x4
x1
x20

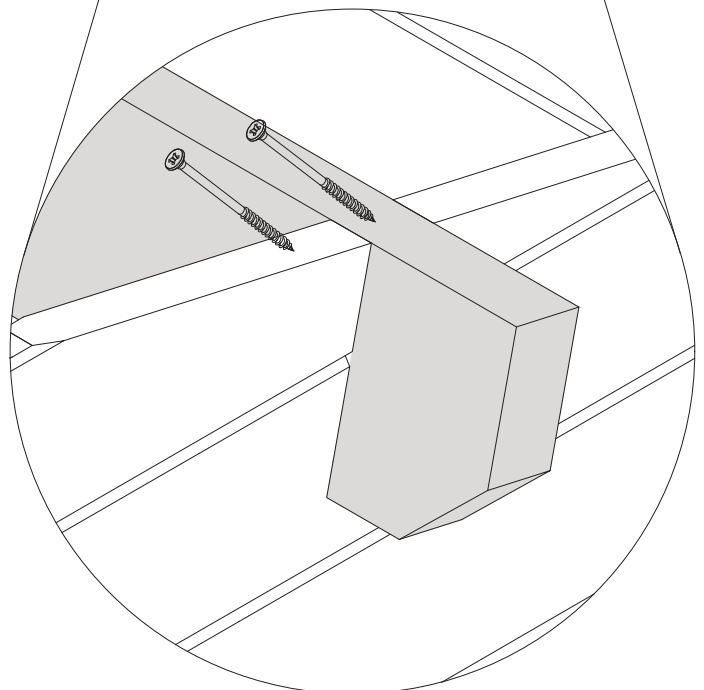
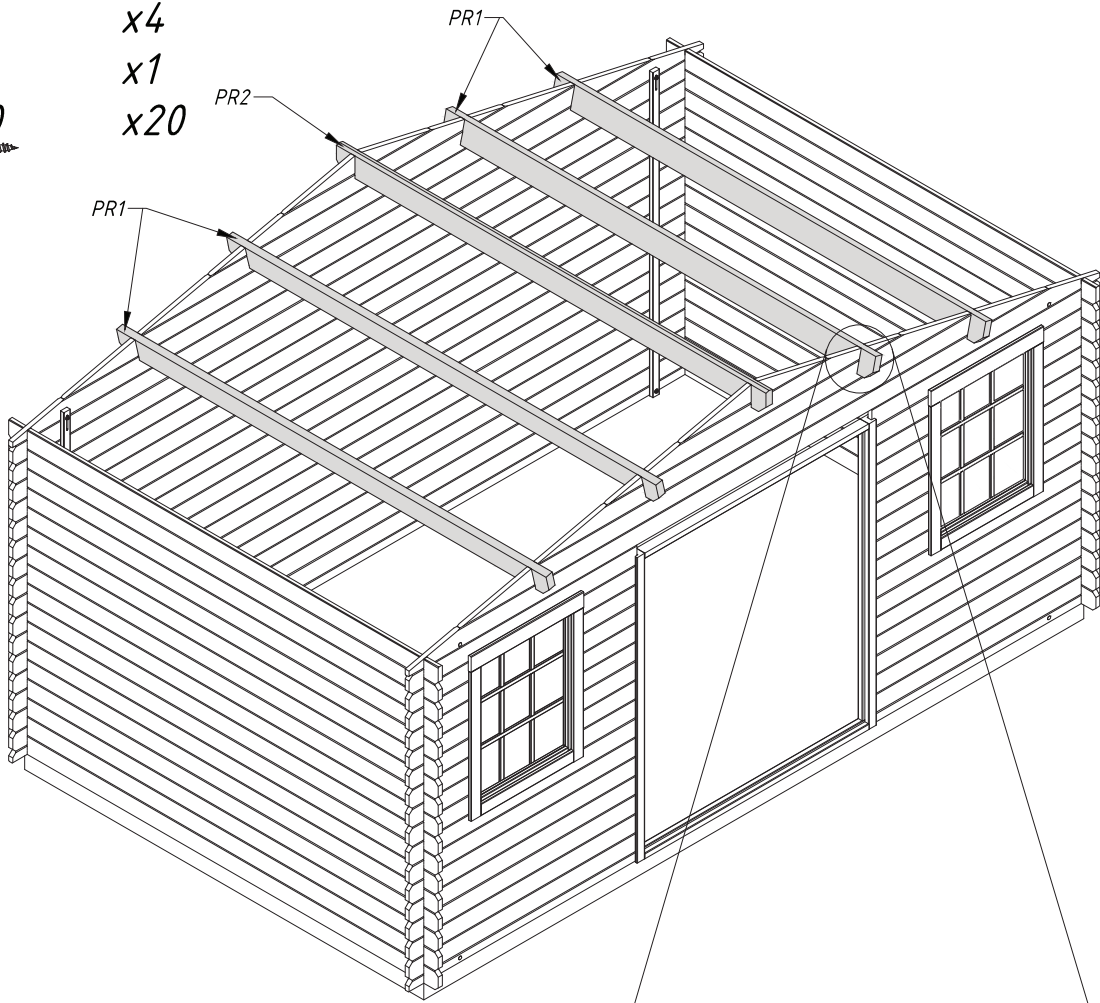

6

OSB3_1
Ø4x50

x10
x332

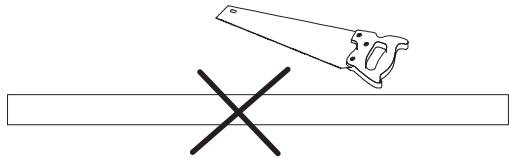
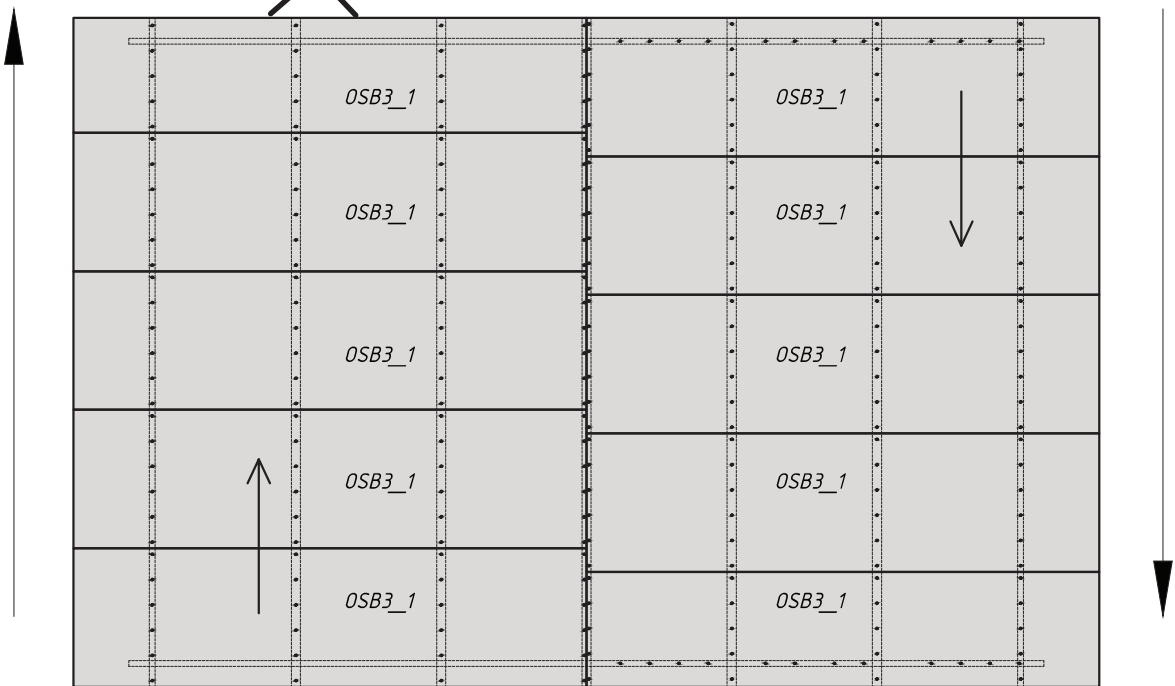
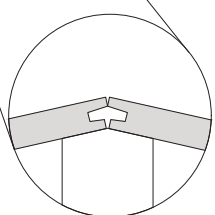
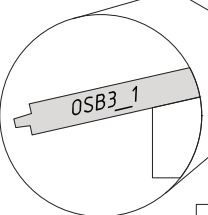
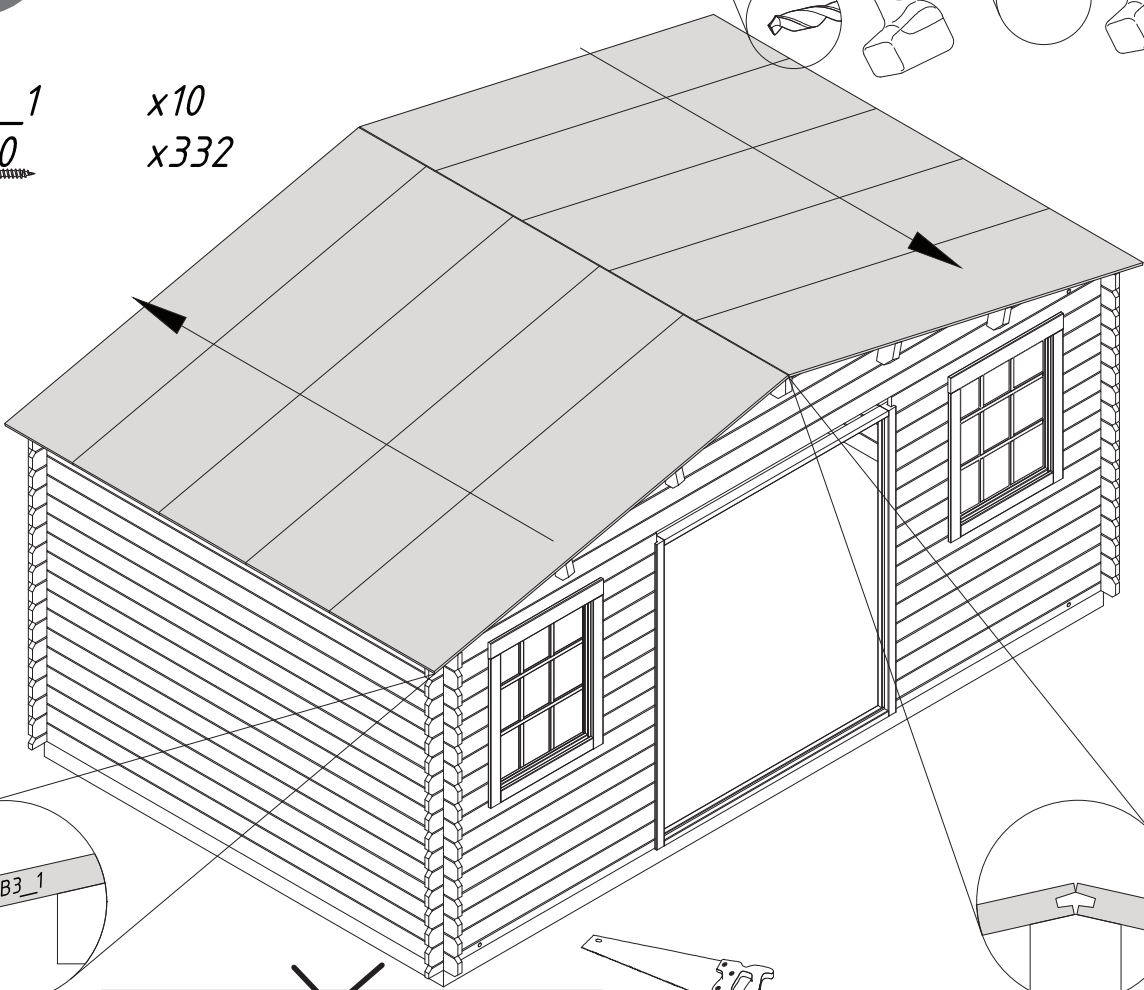
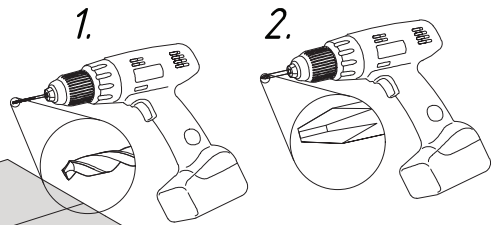

7

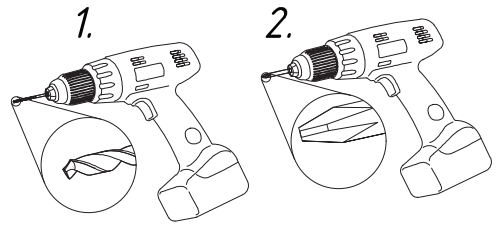

YPapp-1 x2

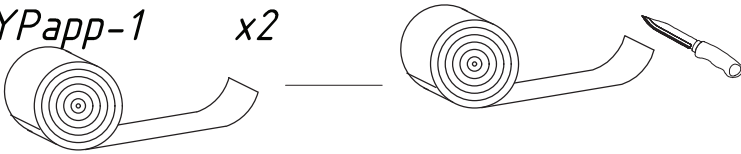

x6

RE1-1 x4
Ø3x30 x20
Ø2x16 x300

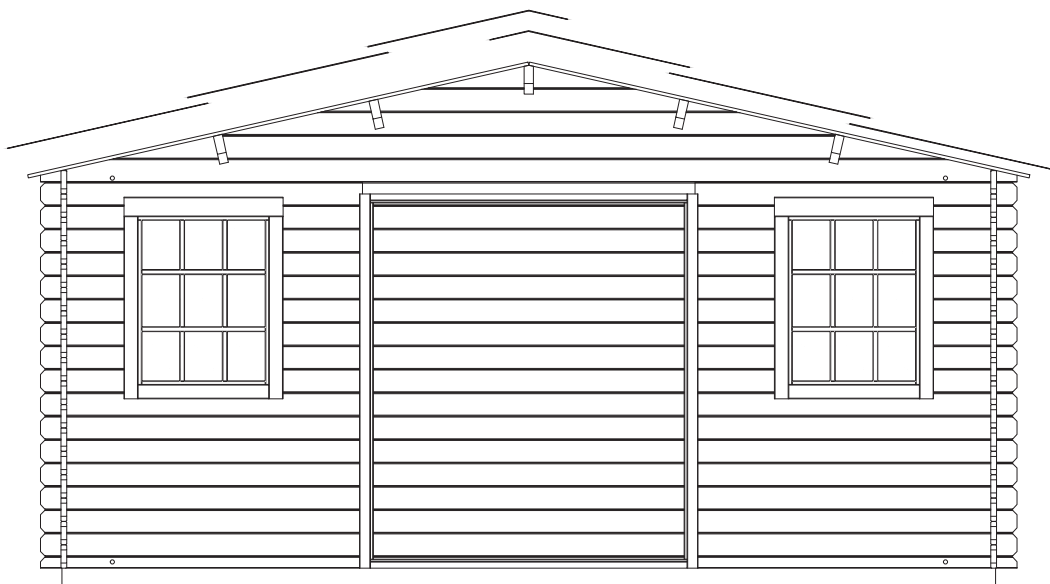
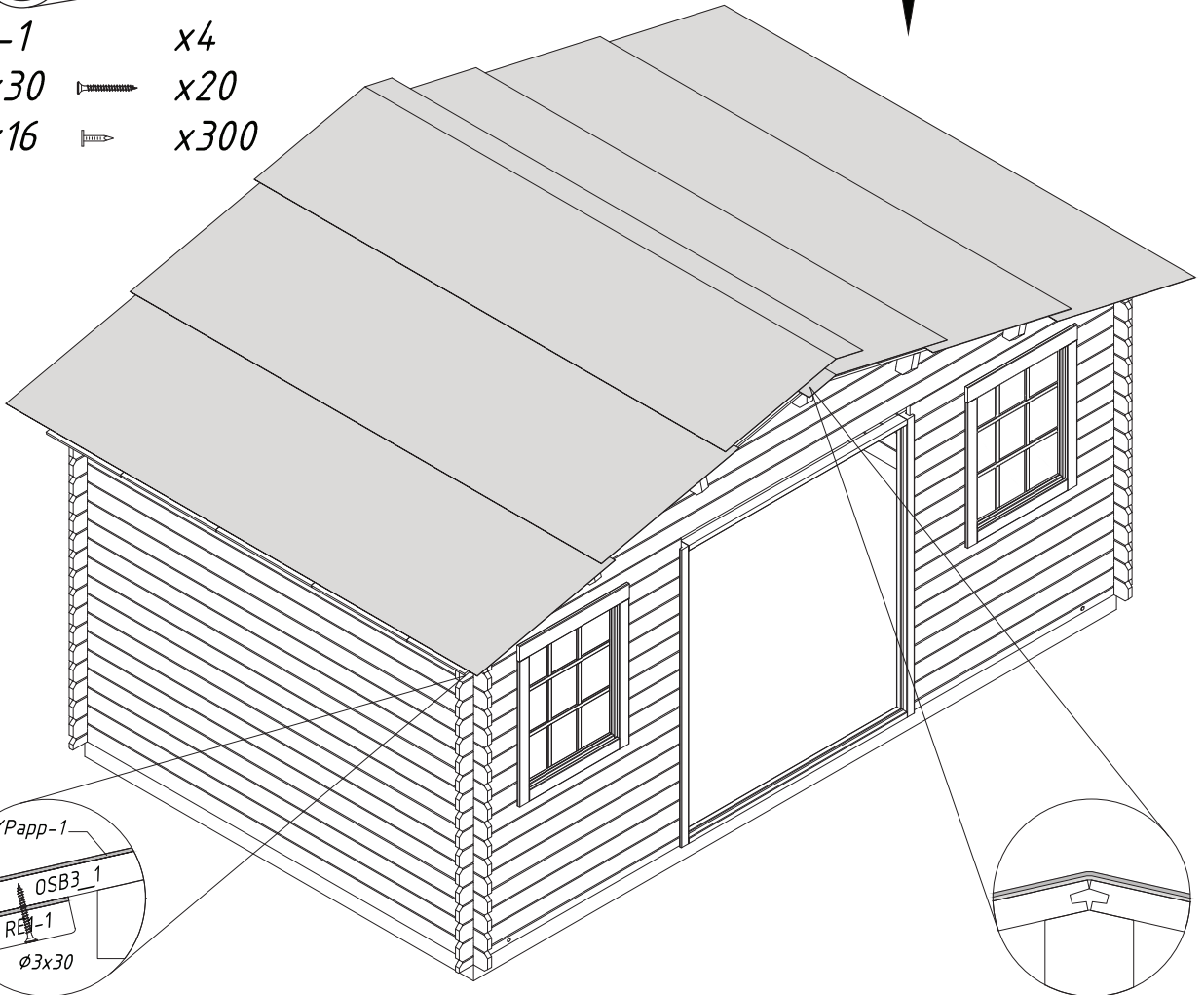

8

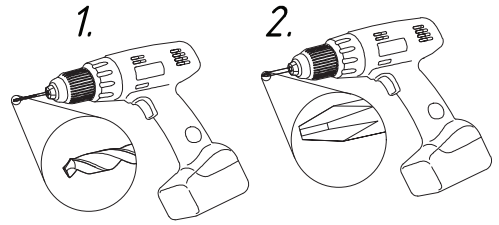

- FaB3-1 x4
 - WB1-1 x4
 - Det1 x2
 - Ø3,5x40 x56
-

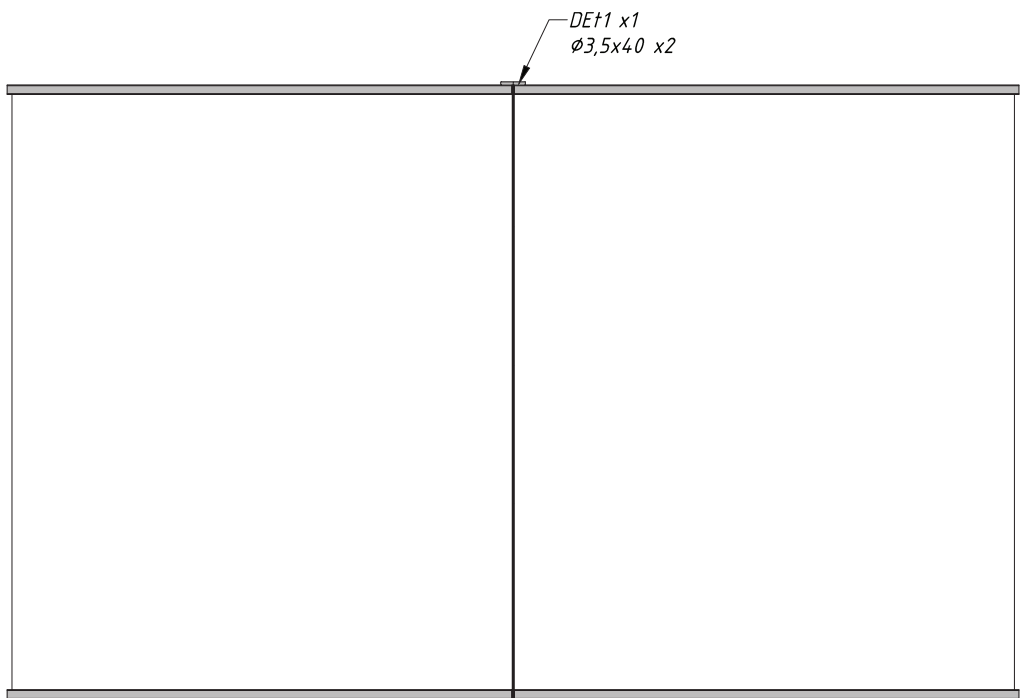
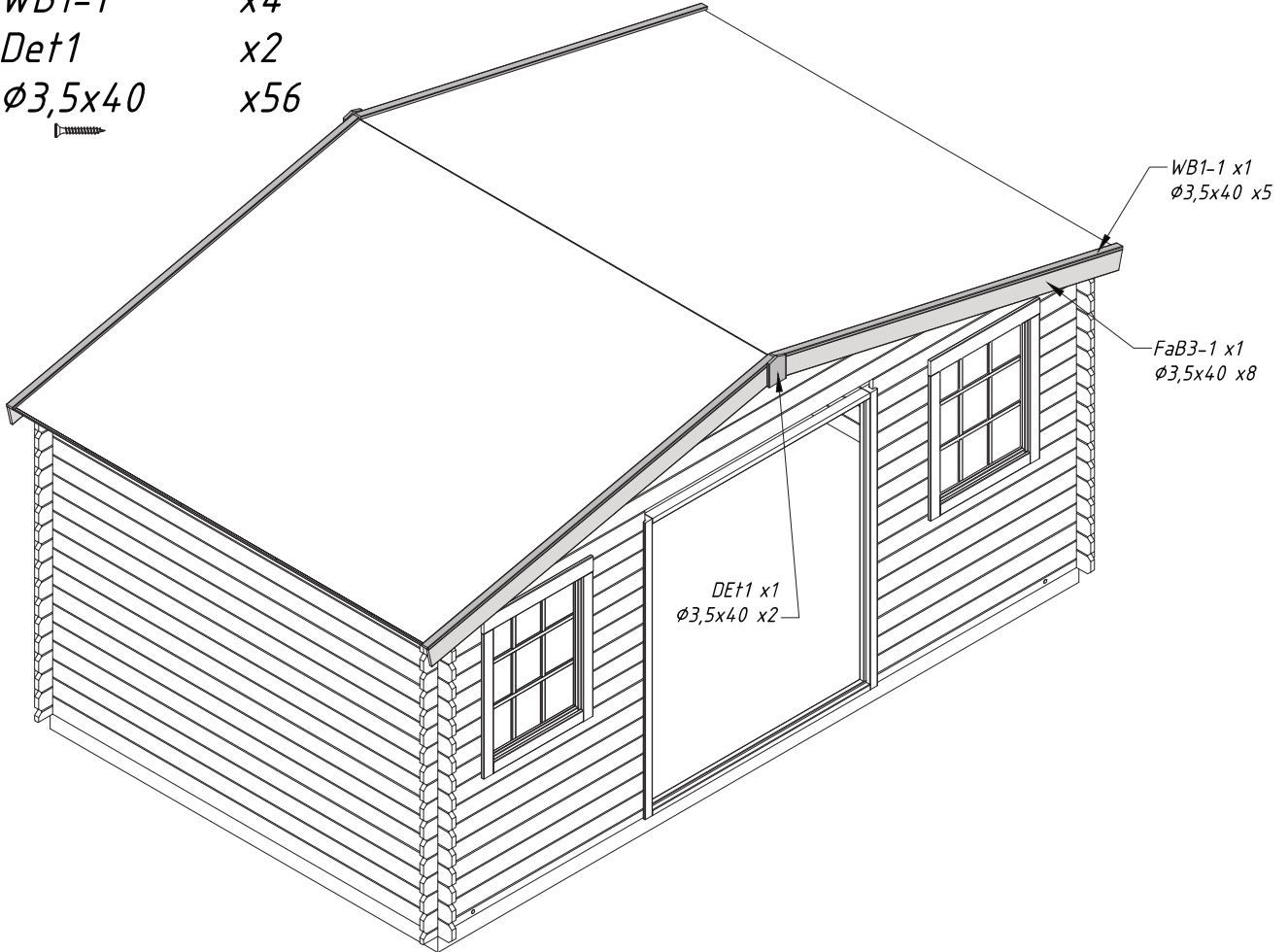

- SIS7-1 x2
- TU28-48P x1
- Ø3x20 x16
- Ø3x30 x10
- Ø2,5x16 x4
- Ø3,5x25 x24
- Ø4x50 x18

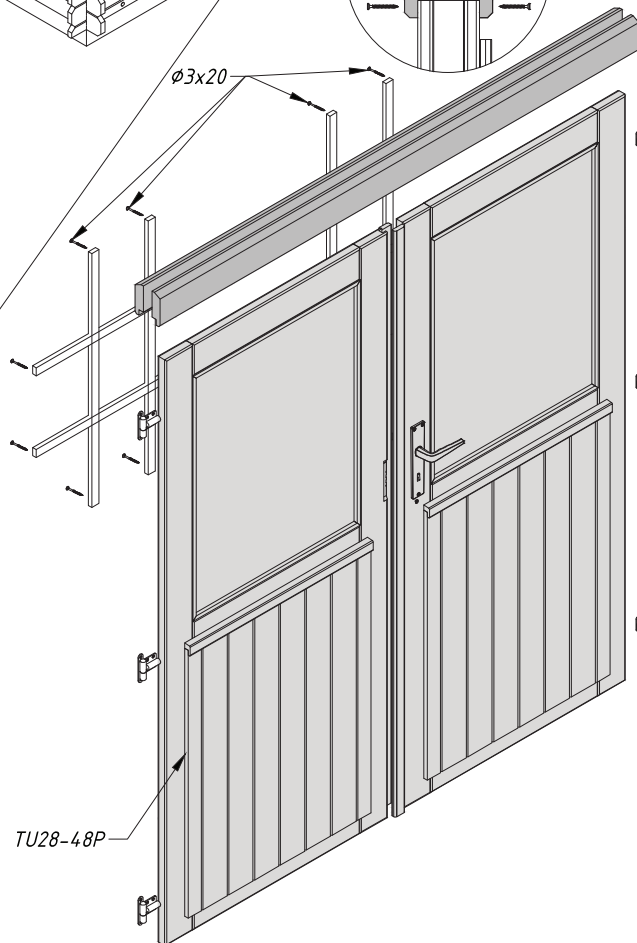
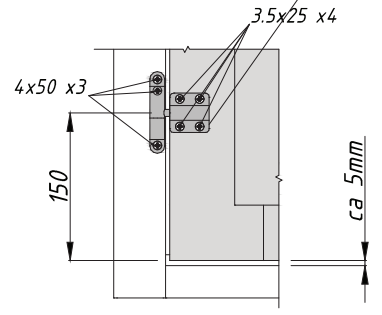
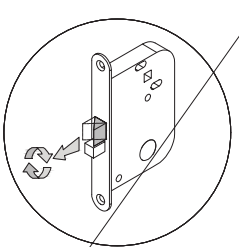
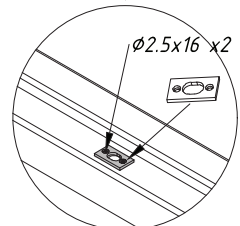
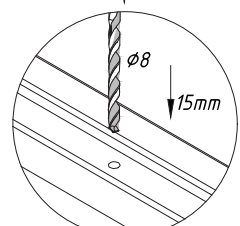
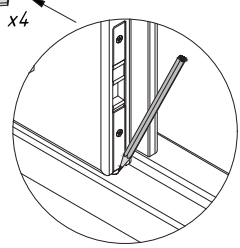
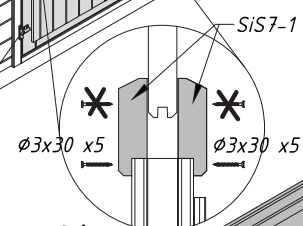
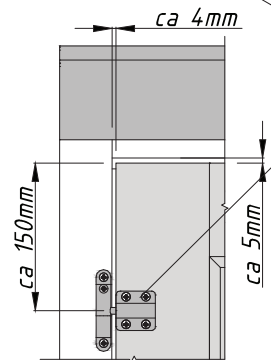
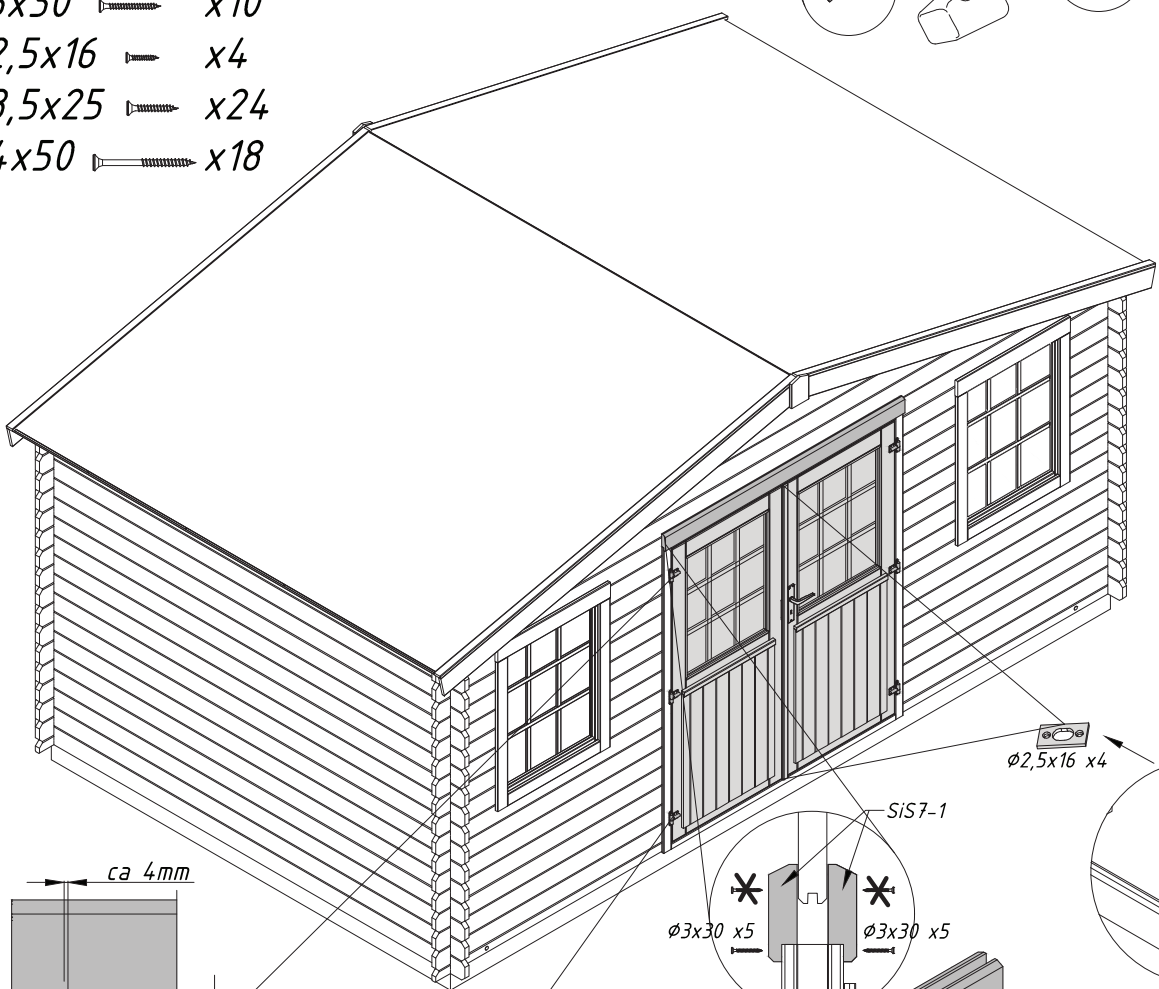
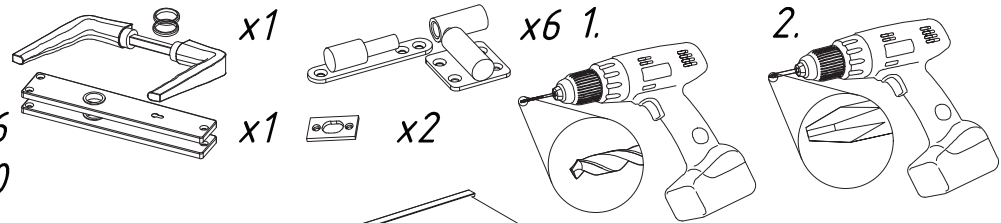

Leroy Merlin France
Rue Chanzy
59260 Lezennes

Made In Estonia

* Garantie 3 ans [couverture 1 an] / Guarantee 3 years [roof 1 year]